



RAISE3D



PIONEERING FLEXIBLE MANUFACTURING



WWW.RAISE3D.COM

About Us

Raise3D has become a global leader in manufacturing precise and reliable 3D printers, with headquarters in the U.S.A., China, and the Netherlands.

Raise3D printers have enjoyed an award winning legacy including: "**3D Printer of the Year**" award from international tech authority Make magazine (along with the annual cover). All3DP, the largest global 3D printing evaluation organization, awarded Raise3D "**Best 3D Printer**" and "**Best Large Format 3D Printer**".

In addition to designing and manufacturing 3D printers used by many of the world's biggest companies, Raise3D also develops powerful slicing software (ideaMaker), an enterprise level cloud-based print management platform (RaiseCloud), and professional consulting services and technologies that result in a one-stop flexible manufacturing solution for our customers.



Pro2 Series
(Page 5)



E2
(Page 21)



ideaMaker
(Page 31)



RaiseAcademy
(Page 34)



RaiseCloud
(Page 35)



2017 | 2018 | 2019

Award-Winning Legacy

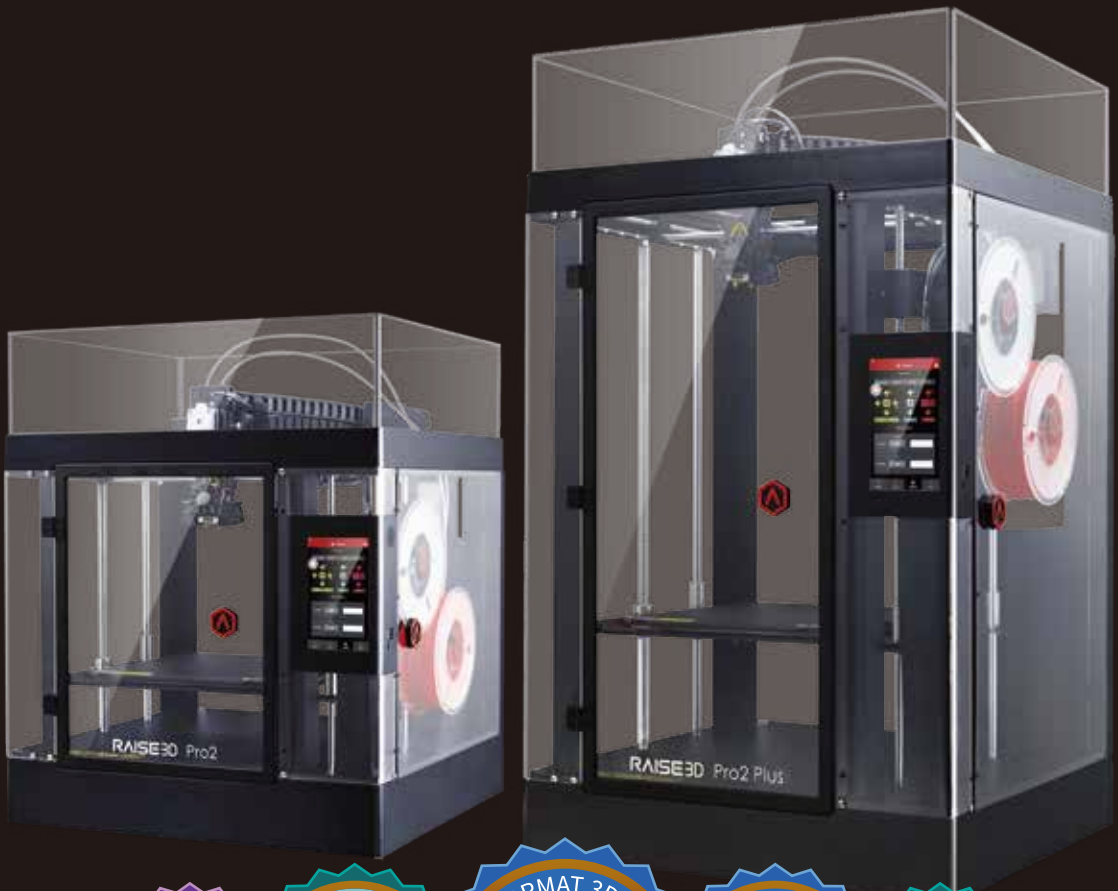

“With upgrades to please everyone from the extruder savvy to the fume conscious, the Pro2 is as close to set-it-and-forget-it as we've seen in a top level machine.”

Kelly Egan
Make Magazine

“The Pro2 is the best-in-class and possibly the best 3D printer on the market.”

Sam Westin
Total 3D Printing

“The build quality of the Raise3D is outstanding, the screen a joy to work with - it's a huge step forward in usability.”

Anatol Locker
All3DP

Pro2 Series 3D Printer

Imagine New Possibilities



Industrial grade printers ready to integrate print factories,
24/7 production capability and customized parts on demand.



Electronic Driven, Dual Extrusion with Retracting Hot Ends;
4× Increased torque performance



Massive Build Volume



0.01mm Layer Height



Camera / HEPA Air Filtration



Diverse Filament Compatibility (Up to 300°C)



32 Bit Motion Control Board



7-inch Touch Screen



Resume Print after Power Loss
or Filament Outage



Wireless Compatibility

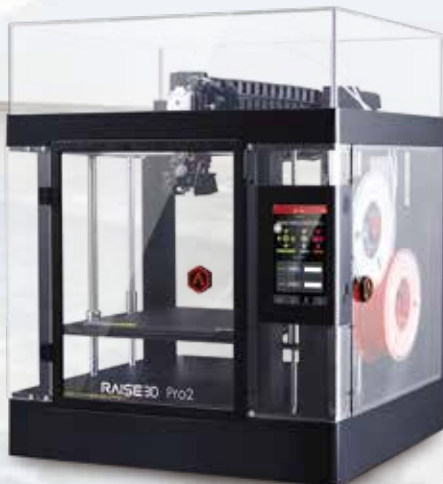

Pro2

12"×12"×11.8"



Pro2 Plus

12"×12"×23.8"

Electronic Driven Dual Extrusion with Retracting Hot Ends

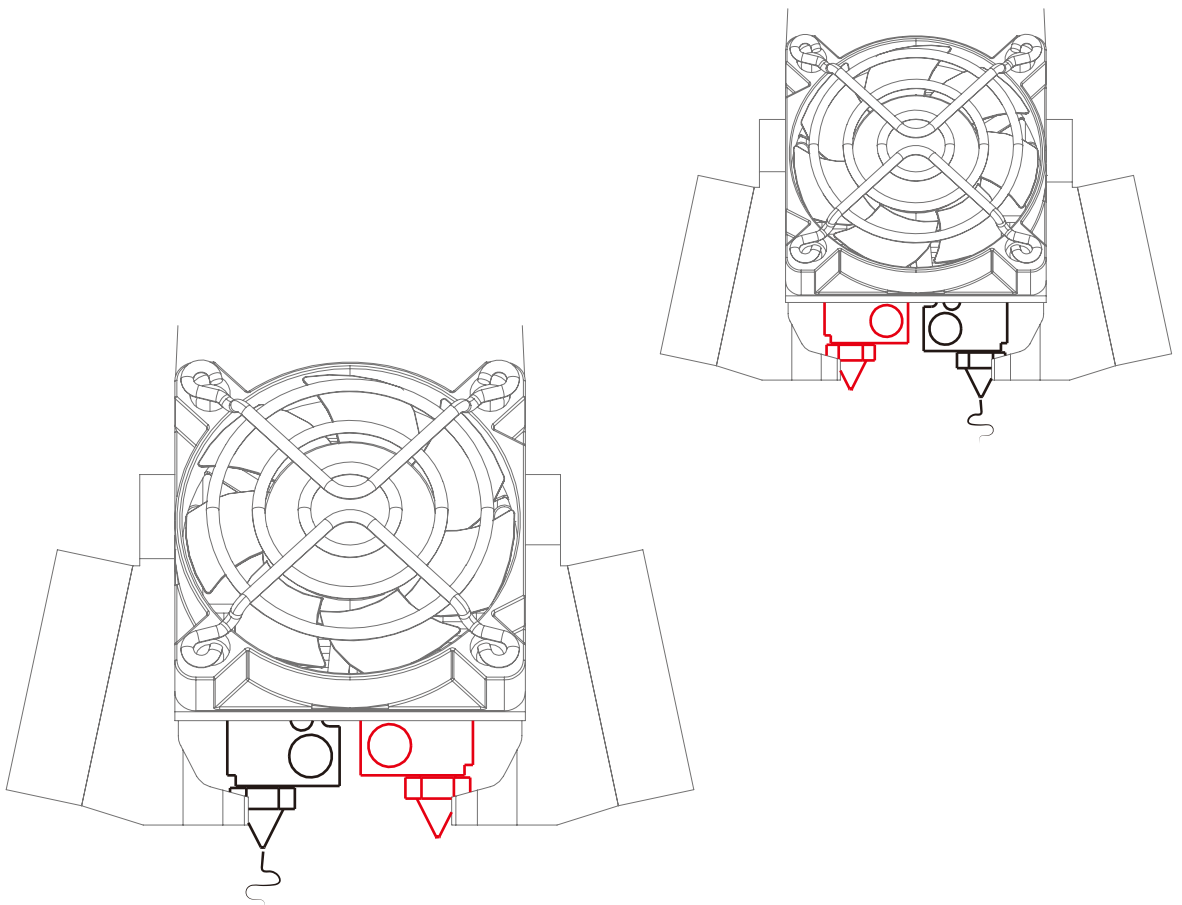



Prints complex mechanical parts

Supports a variety of multi-material prints

Improves print speed

- High repeatability (<math><0.005\text{ m}</math>, 5 micron)
- Lightning speed (<math><1</math> second switching time)
- 1.5 mm lifting distance, compatible with flexible filaments
- High reliability (tested >100,000 times)

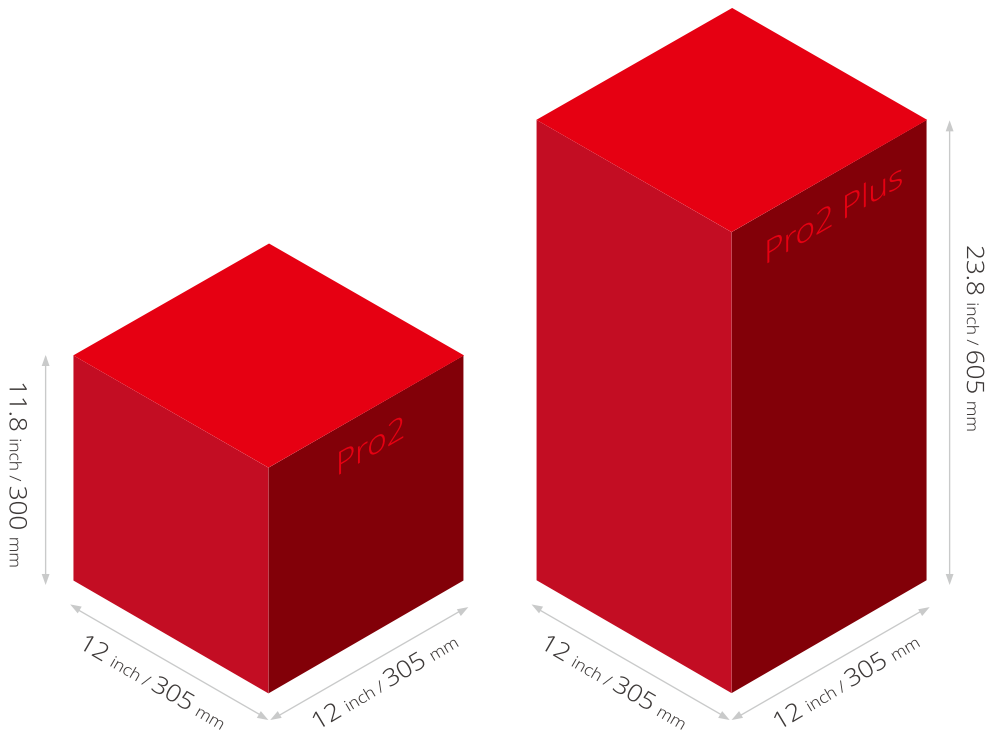

Think Bigger

Up to

12 × 12 × 23.8 inch
305 × 305 × 605 mm

24/7 Reliability - Multiple Fail-Safe Systems - Industrial Grade Components

Capable of Printing a Variety of Filaments up to 300°C

PLA ABS HIPS

PC TPU TPE

NYLON PETG ASA

PP PVA

Glass Fiber Infused

Carbon Fiber Infused

Metal Fill

Wood Fill



High Resolution

Unique motion system for superior part quality and resolution



Interchangeable nozzles:
0.2 mm nozzle for finer X/Y detail



Precise positioning:
0.78125 micron positioning resolution on X/Y axis



Unmatched layer resolution:
0.01 mm layer thickness

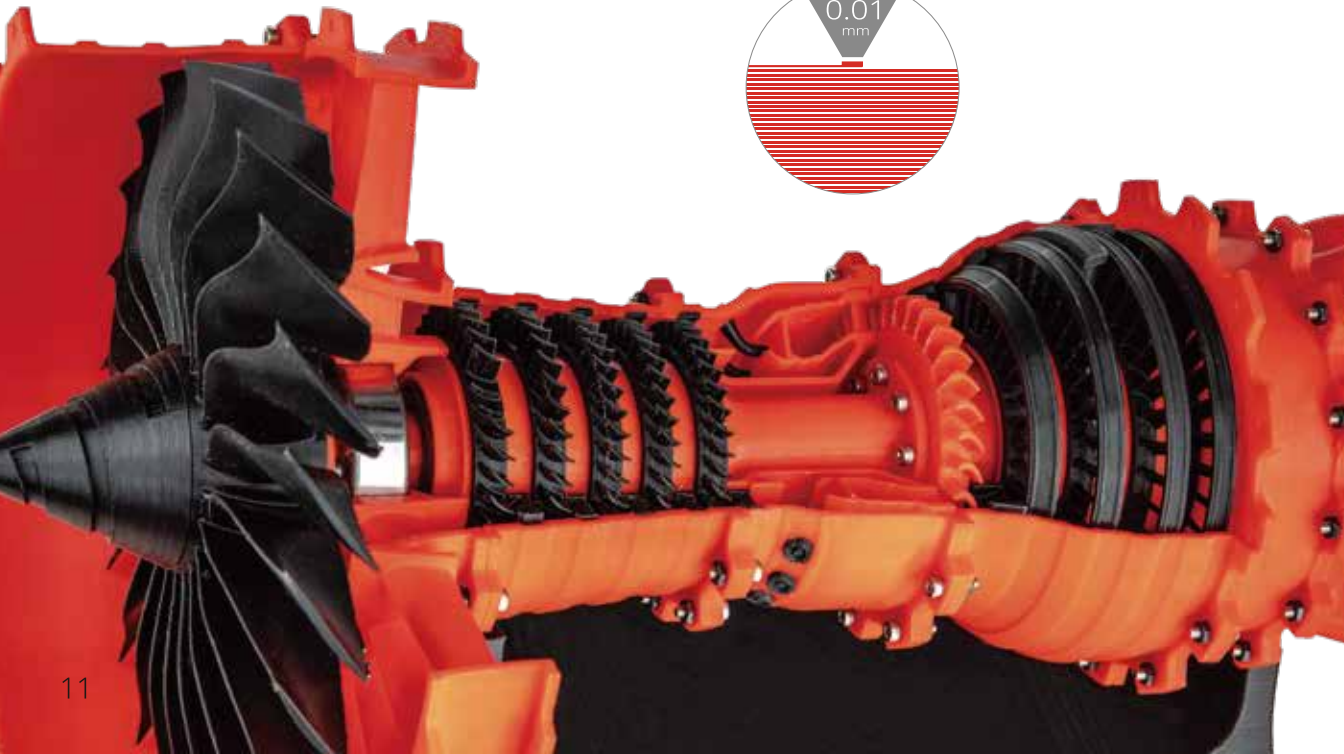
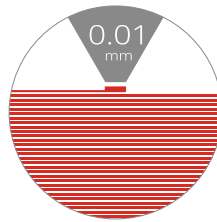

Intuitive User Experience

Visual Interface / Rapid Reviewing

Visual Print Progress / Full Adjustment Control

7-inch Touch Screen



Integrated Setting Control

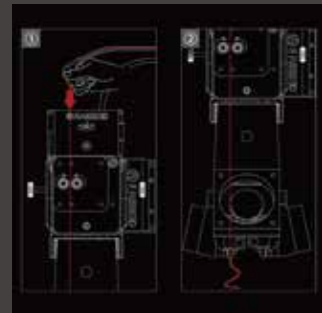

On-screen Assistance

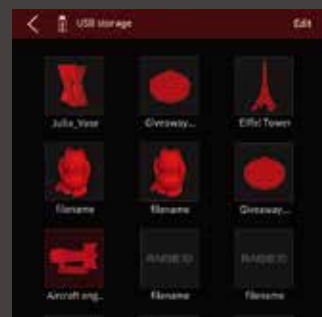

Visual Model Selection

Second Generation Power Loss Resuming

Never lose a print.

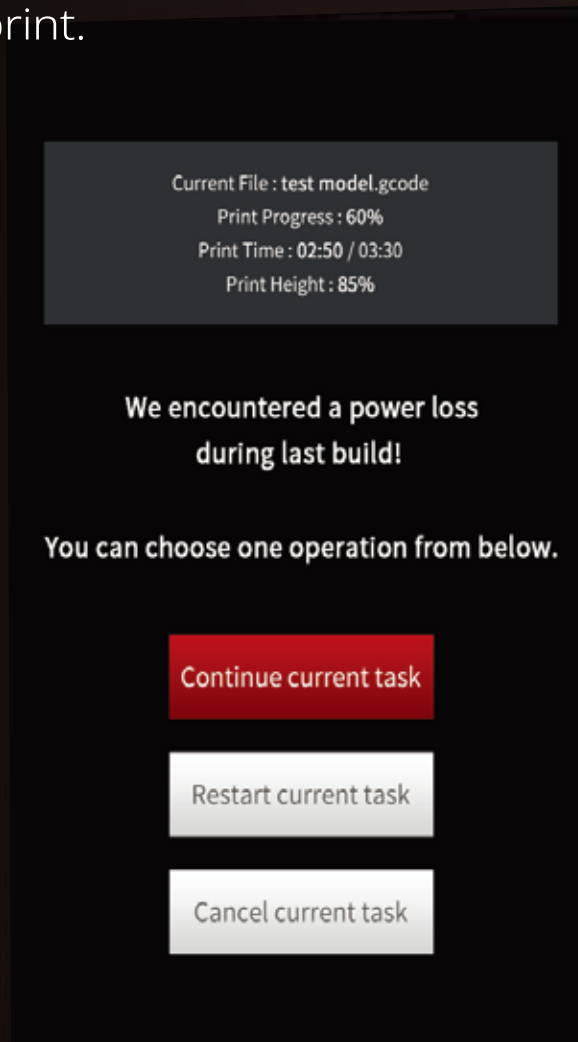

The image shows a dark-themed dialog box on a printer's control panel. At the top, a grey box contains the following text: "Current File : test model.gcode", "Print Progress : 60%", "Print Time : 02:50 / 03:30", and "Print Height : 85%". Below this, the main text reads "We encountered a power loss during last build!". Underneath, it says "You can choose one operation from below.". There are three buttons: a red button labeled "Continue current task", a white button labeled "Restart current task", and another white button labeled "Cancel current task".

Current File : test model.gcode
Print Progress : 60%
Print Time : 02:50 / 03:30
Print Height : 85%

We encountered a power loss
during last build!

You can choose one operation from below.

Continue current task

Restart current task

Cancel current task

Effortless, dependable, and accurate
with optical run-out sensors and end stops.

New Extruder with Filament Run-out Sensor

Better grip

Dual gear driven

No slipping

4× increased torque performance

Worry free prints

Optical run-out sensor

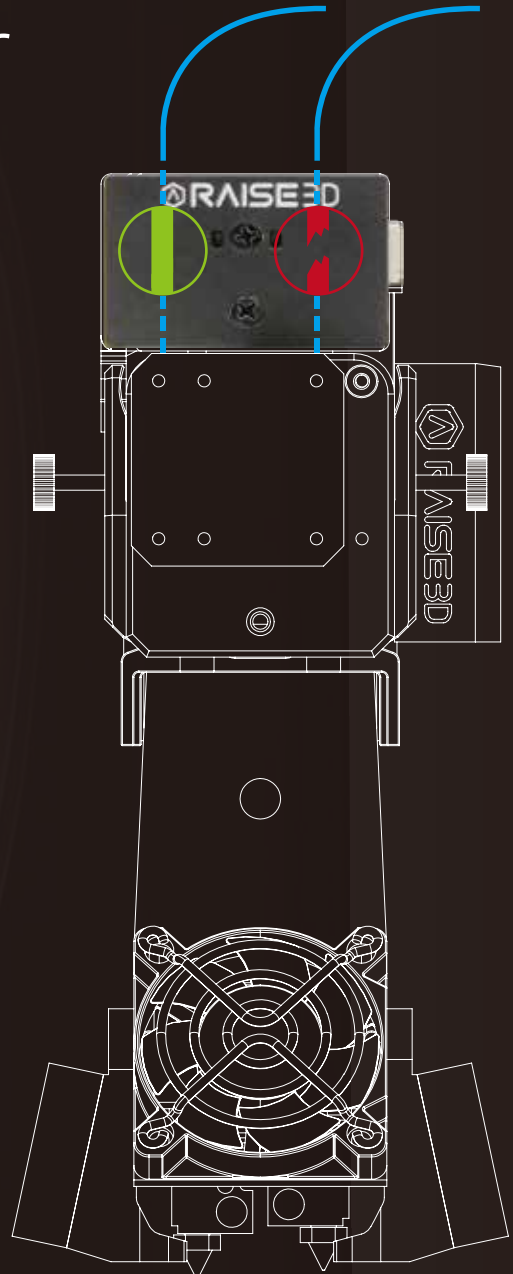

Next Generation Motion Controller

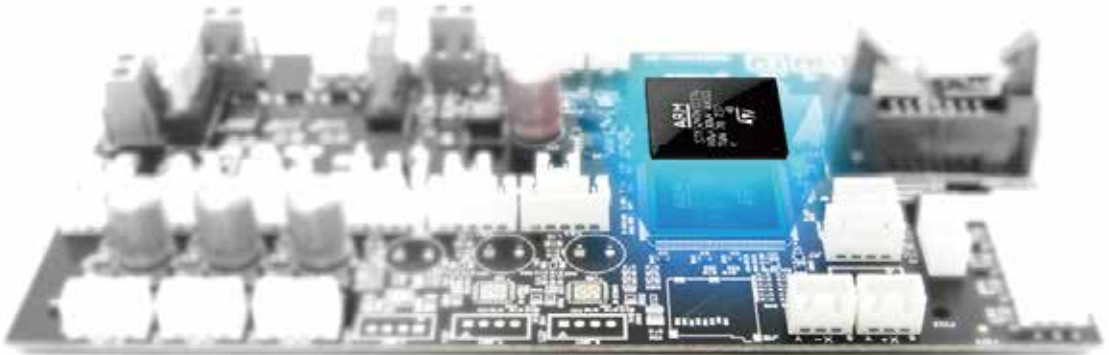

- 400MHz ARM Cortex-M7 32bit RISC FPU
- Industrial grade components
- Stand-alone motor driver
- 256 micro-steps driver system



Best in class reliability
Precise voltage control
Silky smooth movement
Superior thermal performance

Remote User Interface

Access - Monitor - Control

Operate efficiently with ideaMaker by connecting wirelessly to your Pro2 Series Printer.



Wireless Upload

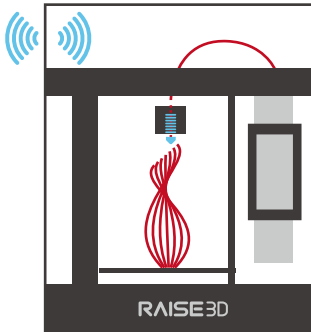

Wireless Control



Wireless Monitoring

HEPA Air Filtration



Workspace friendly.
Designed to silently remove nano-particles.

Build Plate System

Excellent warping prevention

Even heat distribution

Longer lifetime

Easy to remove



RAISE3D

- Aerospace grade material
- High temperature silicone heating bed
- Magnetically-held aluminium bed
- Improved 4+9 points lock system

More Features

- Built-in camera
- State of the art extruder system
- Improved factory calibration
- High quality optical end stops
- Software controlled active cooling fan
- Advanced hot end



ITEM	Pro2		Pro2 Plus	
CONSTRUCTION	Build Volume (W×D×H)			
	Single Extrusion Print	Dual Extrusion Print	Single Extrusion Print	Dual Extrusion Print
	12×12×11.8 inch 305×305×300 mm	11×12×11.8 inch 280×305×300 mm	12×12×23.8 inch 305×305×605 mm	11×12×23.8 inch 280×305×605 mm
	Machine Size (W×D×H)			
	24.4×23.2×29.9 inch 620×590×760 mm		24.4×23.2×43.5 inch 620×590×1105 mm	
ELECTRICAL	Power Supply Input Power Supply Output	100-240 V AC, 50/60 Hz 230 V @ 3.3 A 24 V DC, 600 W		
PRINTER	Print Technology Print Head Filament Diameter XYZ Step Size Print Head Travel Speed Build Plate Max Build Plate Temperature Heated Bed Material Build Plate Leveling Supported Materials Nozzle Diameter Max Nozzle Temperature Connectivity Noise Emission (Acoustic) Operating Ambient Temperature Storage Temperature Technical Certifications Filter	FFF Dual-head with electronic lifting system 1.75 mm 0.78125, 0.78125, 0.078125 micron 30-150 mm/s Heated aluminum build plate with magnetic holding 110 °C Silicone Pre-calibrated leveling PLA/ ABS/ HIPS/ PC/ TPU/ TPE/ NYLON/ PETG/ ASA/ PP/ PVA/ Glass Fiber Infused/ Carbon Fiber Infused/ Metal Fill/ Wood Fill 0.4 mm (Default), 0.2/ 0.6/ 0.8/ 1.0 mm (Available) 300 °C Wi-Fi, LAN, USB port, Live camera <50 dB(A) when building 15-30 °C, 10-90% RH non-condensing -25 to 55 °C, 10-90% RH non-condensing CB, CE, FCC, RoHS HEPA filter with activated charcoal		
SOFTWARE	Slicing Software Supported File Types Supported OS Machine Code Type	ideaMaker STL/ OBJ/ 3MF Windows/ macOS/ Linux GCODE		
PRINTER CONTROLLER	User Interface Network Resume Print after Power Outage Screen Resolution Motion Controller Logic Controller Memory Onboard Flash OS Ports	7-inch Touch Screen Wi-Fi, Ethernet Firmware recording, no need for battery installation. 1024*600 Atmel ARM Cortex-M7 400MHz FPU Freescale i.MX6, Quad core 1Ghz ARM processor 1GB 8GB Embedded Linux USB 2.0*2, Ethernet*1		

E2 3D Printer

Precise, Reliable, and Affordable



An easy-to-use, durable desktop 3D printer ready to increase precision standards, scale production, and add a powerful new manufacturing resource.



Mirror Mode



Duplication Mode



Auto Bed
Leveling



Industry First Video-Assisted
Offset Calibration System



Safety Features



Power Saving
Button



Flexible Build
Plate



Variety of Material
Compatibility

IDEX (Independent Dual Extruders) Multiple Prints Simultaneously



Mirror Mode

Produce 3D models and their inverse simultaneously,
increasing productivity and reducing print time.



Duplication Mode

Use both extruders in synchronized printing, doubling production capabilities.

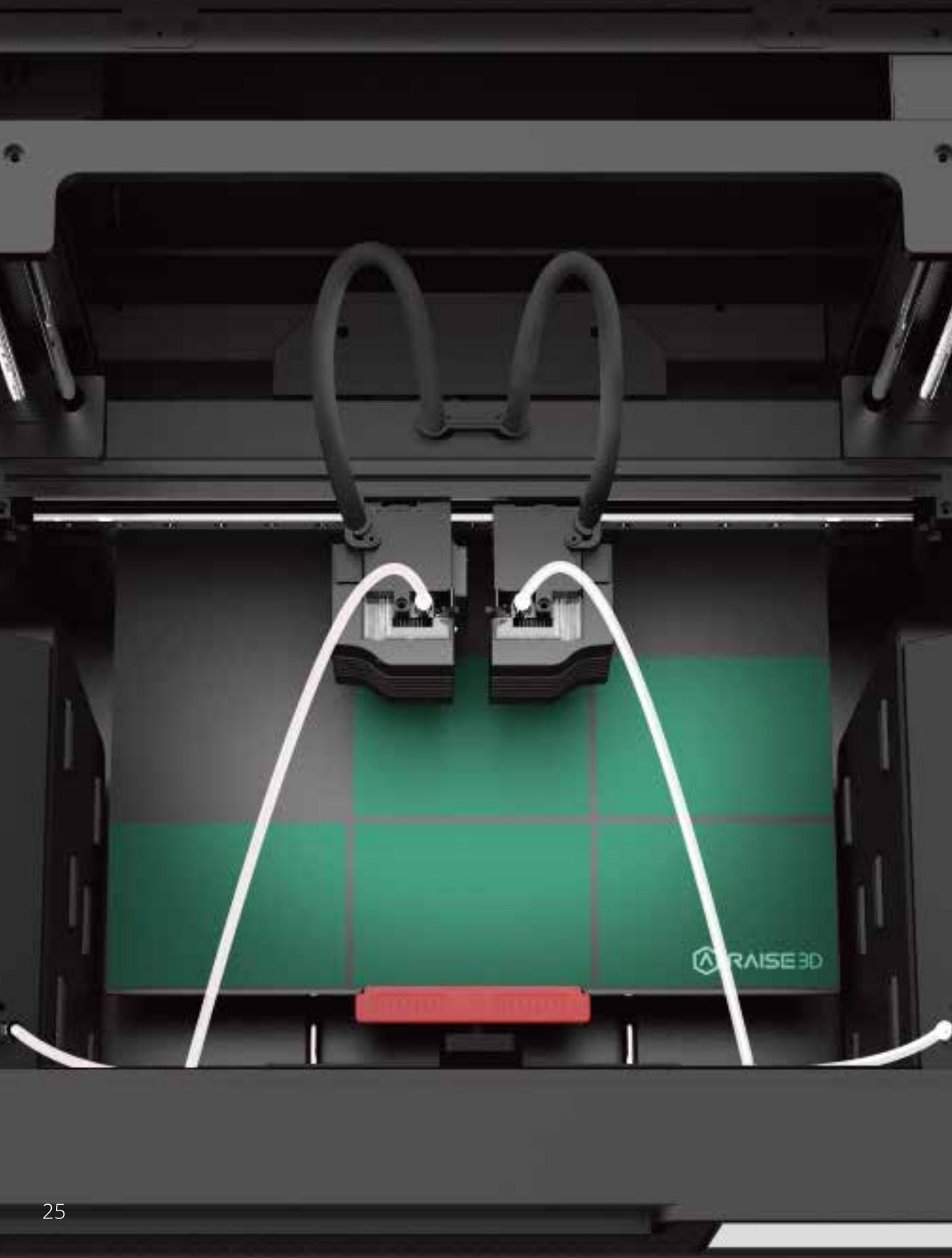

Auto Bed Leveling

Confirms the printing platform is level whenever preparing to print. ABL maintains the distance between the print nozzles and bed, creating a uniform build area.

Improves bed adhesion and print quality by allowing the extruder to adjust to even minor surface contour changes.

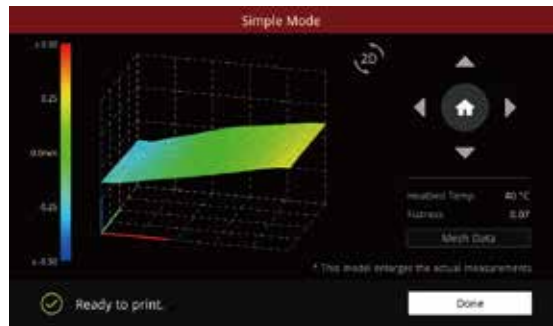

Industry First Video-Assisted Offset Calibration System

Spend less time calibrating and more time printing.



Safety Features

Opening a door is detected automatically, immediately pausing the print and keeping users safe.



Power Saving Button

Turn off the RaiseTouch and LED lights to save energy and print throughout the night.



Flexible Build Plate

Easily remove prints from the flexible build plate while minimizing potential print damage to quickly return to printing.



Variety of Material Compatibility

Shortened feed paths greatly enhances the printing capability for soft materials like TPU.



More Features

- Power Loss Recovery
- Filament Run-out Sensor
- Remote Video Monitoring
- HEPA Air Filtration
- Remote User Interface
- 7-inch Touch Screen
- Capable of Printing a Variety of Filaments up to 300°C

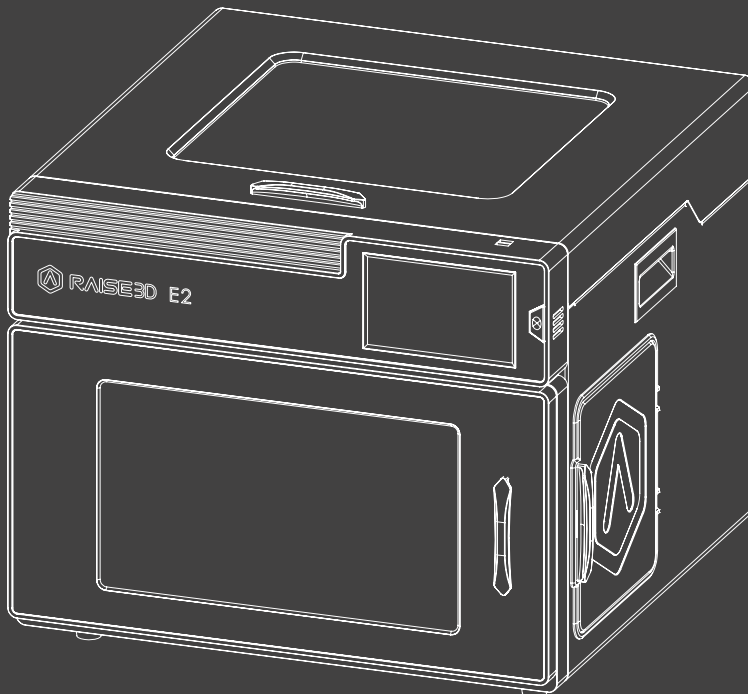

ITEM	E2	
CONSTRUCTION	Build Volume (W×D×H)	
	Single Extruder Print	Dual Extruder Print
	13×9.4×9.4 inch / 330×240×240 mm	11.6×9.4×9.4 inch / 295×240×240 mm
	Machine Size (W×D×H)	
	23.9×23.5×18.3 inch / 607×596×465 mm	
ELECTRICAL	Power Supply Input	100-240 V AC, 50/60 Hz 230 V @ 2 A
	Power Supply Output	24 V DC, 350 W
PRINTER	Print Technology	FFF
	Motion System	Independent Dual Extruders
	Filament Diameter	1.75 mm
	XYZ Step Size	0.78125, 0.78125, 0.078125 micron
	Print Head Travel Speed	30 - 150 mm/s
	Build Plate	Flexible Steel Plate with Buildtak
	Max Build Plate Temperature	110 °C
	Heated Bed Material	Silicone
	Build Plate Leveling	Mesh-leveling with Flatness Detection
	Supported Materials	PLA/ ABS/ HIPS/ PC/ TPU/ TPE/ NYLON/ PETG/ ASA/ PP/ PVA/ Glass Fiber Infused/ Carbon Fiber Infused/ Metal Fill/ Wood Fill
	Nozzle Diameter	0.4 mm (Default), 0.2/ 0.6/ 0.8/ 1.0 mm (Available)
	Hotend	V3P (V3 hotend with PTFE version)
	Max Nozzle Temperature	300 °C
	Connectivity	Wi-Fi, LAN, USB port, Live camera
	Noise Emission (Acoustic)	< 50 dB(A) when building
	Operating Ambient Temperature	15 - 30 °C, 10 - 90% RH non-condensing
	Storage Temperature	-25 to 55 °C, 10 - 90% RH non-condensing
	Technical Certifications	CB, CE, FCC, RoHS
	Filter	HEPA filter with activated charcoal
SOFTWARE	Slicing Software	ideaMaker
	Supported File Types	STL/ OBJ/ 3MF
	Supported OS	Windows/ macOS/ Linux
	Machine Code Type	GCODE
PRINTER CONTROLLER	User Interface	7-inch Touch Screen
	Network	Wi-Fi, Ethernet
	Resume Print after Power Outage	Firmware recording, no need for battery installation.
	Screen Resolution	1024*600
	Motion Controller	Atmel ARM Cortex-M4 120MHz FPU
	Logic Controller	NXP ARM Cortex-A9 Quad 1 GHz
	Memory	1 GB
	Onboard Flash	8 GB
	OS	Embedded Linux
	Ports	USB 2.0*2, Ethernet*1

ideaMaker

Powerful Slicing Software



Model repairing

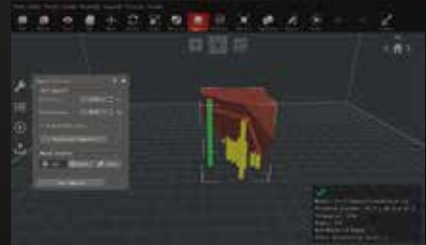

Customizable manual support



Remote management

Adaptive Layer Height, Modifiers,
Sequential Printing

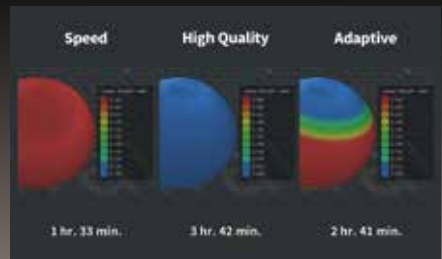

Speed

- Rapid and efficient
- Native-compiled, multi-threaded, 64-bit

Advanced Features

- Adaptive Layer Height, Modifiers, Sequential Printing
- Automated part separation for Multi-Part prints
- Repair and optimize unprintable files
- Cut models at any axis or angle

Support

- Custom Supports/Automatically generated supports
- Manual support and editing features

Optimized Interface

- Create and manage profiles to easily switch between settings
- Cross section viewing
- Auto-layout for multi-part printing
- User friendly UI
- Print in only 2 clicks

Compatibility

- Compatible with most FFF 3D Printers
- Input STL/OBJ/3MF, Outputs GCODE
- Available in English, German, French, Italian, Russian, Polish, Japanese, Korea, Chinese and more

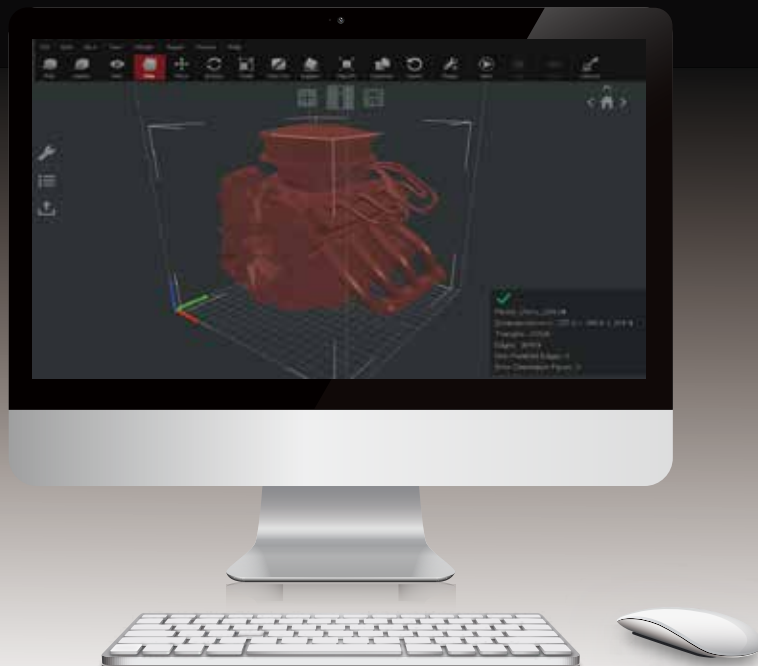



Learn from our experts

In-Depth Tutorials
Advanced Features
Tips and Techniques
and MORE



RAISE

—ACADEMY—

Expert instruction, training and tips

Subscribe free Today  *Raise3D*

youtube.com/raise3d

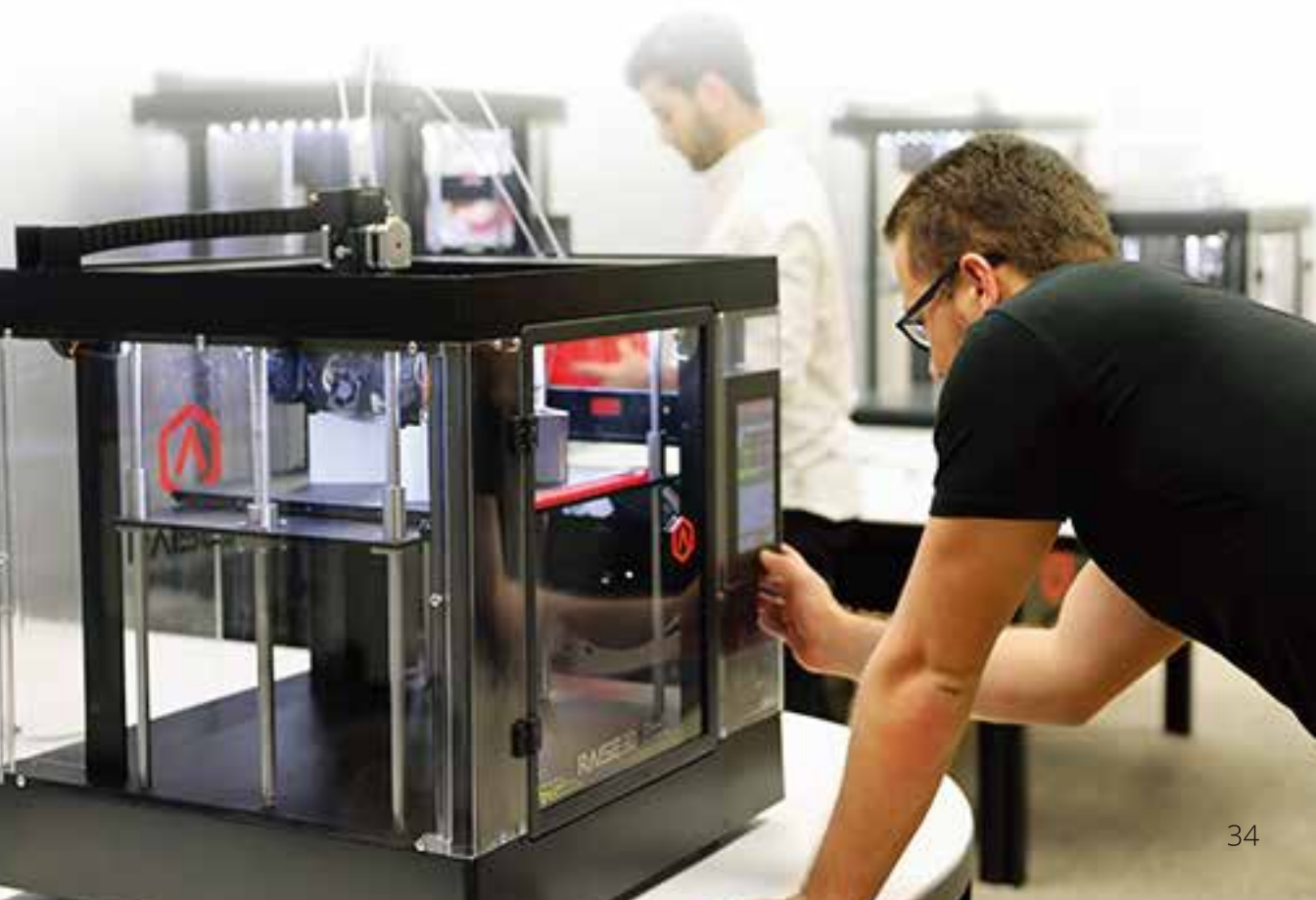



A smarter way to print.



The sky is the limit with **RaiseCloud**

RaiseCloud is the total management solution for enterprise level production. Manage a network of machines and coordinate a team of users with the ease and full control of a centralized platform.

Efficient Printing

Private and shared storage for team collaboration and automated work orders.

Operate Anywhere

Your complete command center all in one central hub. Total control at the click of a button.

Total Management

Assign tasks and monitor progress with at-a-glance reports, camera monitoring and more.



Raise3D Network

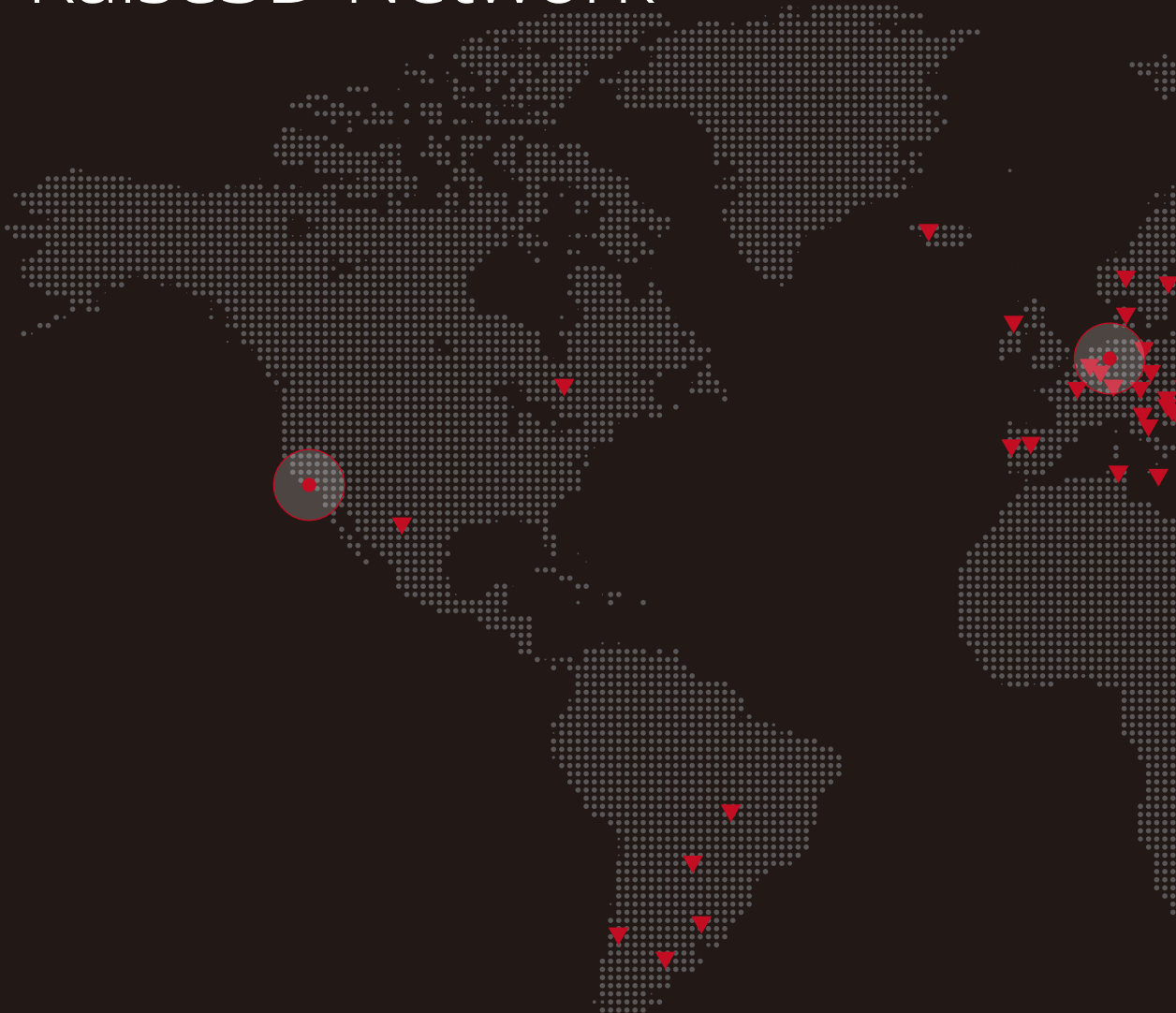

AMERICAS

- Argentina
 - Brazil
 - Canada
 - Ecuador
 - Mexico
 - Paraguay
 - Peru
 - Uruguay
- United States**

EUROPE

- Albania
- Andorra
- Austria
- Belarus
- Belgium
- Bosnia-Herzegovina
- Bulgaria
- Croatia
- Czech Republic
- Denmark
- Estonia
- Finland
- France
- Germany
- Gibraltar
- Hungary
- Iceland
- Ireland
- Italy
- Kosovo
- Latvia
- Lithuania
- Luxembourg
- Macedonia
- Malta
- Montenegro
- Netherlands**
- Norway
- Poland
- Portugal
- Romania
- Russia

▼ SALES PARTNER

● RAISE3D OFFICE

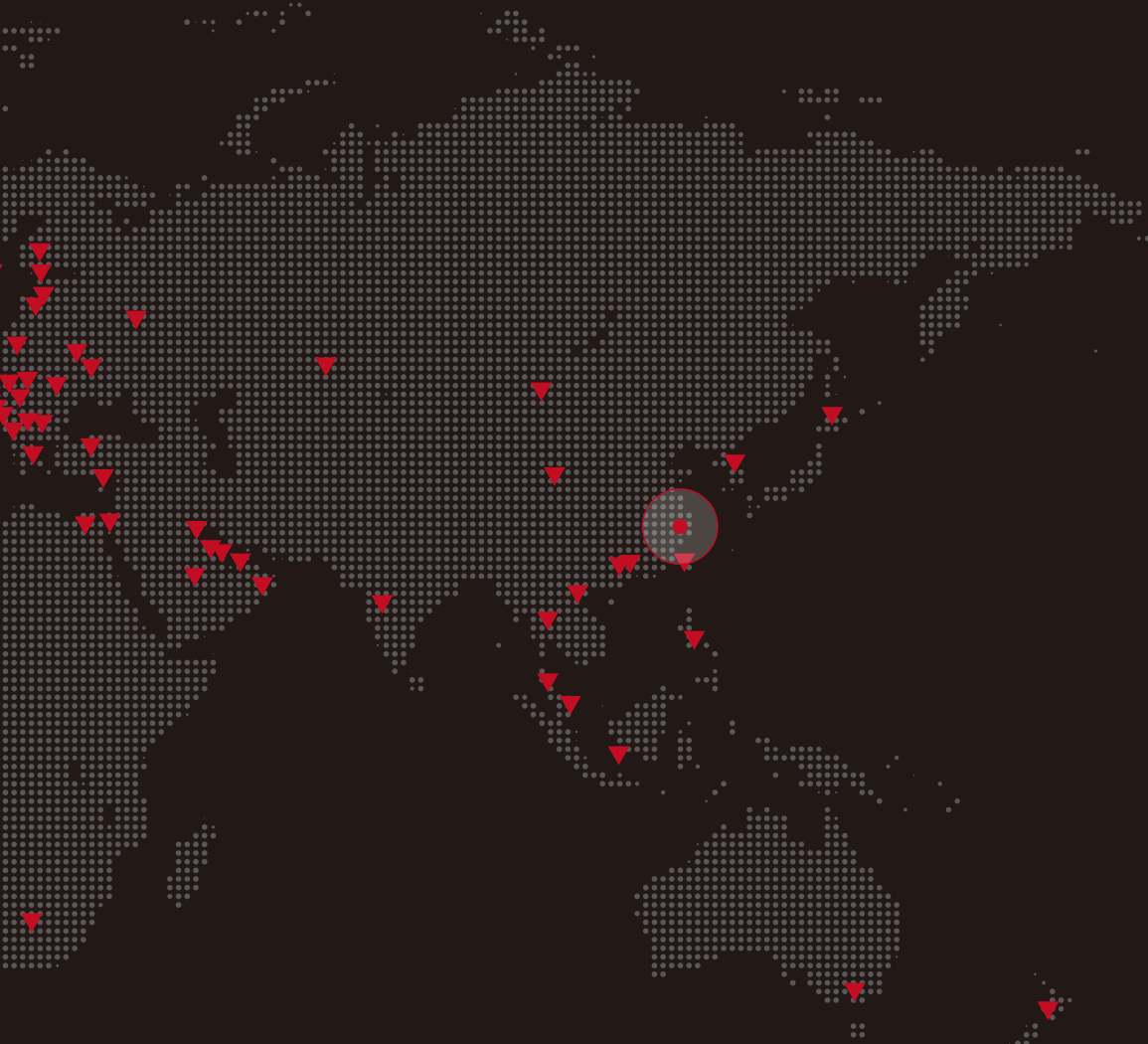

ASIA PACIFIC

San Marino
Serbia
Slovakia
Slovenia
Spain
Sweden
Switzerland
Turkey
Ukraine
United Kingdom

Australia
Bangladesh
Bhutan
China Mainland
Hong Kong
India
Indonesia
Japan
Kazakhstan
Malaysia
Macao
Nepal
New Zealand
Pakistan
Philippines
Singapore
South Korea
Sri Lanka
Taiwan
Thailand

AFRICA & MIDDLE EAST

Algeria
Egypt
Israel
Kuwait
Lebanon
Morocco
Oman
Qatar
Saudi Arabia
South Africa
Tunisia
UAE

43 Tesla, Irvine, CA 92618
USA
+1-888 963 9028

Stationsplein 45
Unit A4.004 3013AK Rotterdam
the Netherlands

Floor 4 B5, 1688 North Guoquan Road,
Yangpu District Shanghai 200438
China

inquiry@raise3d.com

